



**CITY OF
MOUNT
DORA**

**Parks and Recreation
900 N. Donnelly St.
Mount Dora, FL 32757
352-735-7183
Fax: 352-735-3681**

E-mail: publicarts@cityofmoundora.com

**PUBLIC ARTS COMMISSION MEETING
City Hall Board Room, 510 N. Baker Street, Mount Dora, FL 32757
May 27, 2025 at 3:30 PM**

AGENDA

- I. Call to Order
- II. Roll Call
 - A. Election of 2025 Chair and Vice-Chair
- III. Approval of Minutes
 - A. March 25, 2025 Public Arts Commission Meeting Minutes
- IV. Public Comment
- V. Presentations
 - A. Gift of Freenotes Harmony Park Sculpture - Cathy Lunday, Library Director
- VI. Action Items
 - A. Noblewins Art Seating
 - B. Release of Reserved Funds for the Aerial Display Program
- VII. Resolutions
- VIII. Ordinances
- IX. Discussion Items
- X. City Staff
 - A. Staff Update
- XI. Communications and Reports
 - A. Commission Member Lindsay Perreault
 - B. Commission Member John Wesner

- C. Commission Member Thomas Decker
- D. Commission Member Jane Slivka
- E. Commission Member Maryann McNamara
- F. Commission Member Keashawn "Kay" Volmar
- G. Commission Member Rebecca Owen

XII. Future Meeting Dates

- A. July 22, 2025, 3:30 p.m.
- B. September 23, 2025, 3:30 p.m.
- C. November 25, 2025, 3:30 p.m.

XIII. Adjournment

NOTICE: Please note that, for purposes of Section 286.011, Florida Statutes, two or more members of the City Council may be present at this meeting, and this meeting may be considered a City Council meeting.

NOTICE: If any person decides to appeal any decisions at this meeting with respect to any matter considered, such person may need a record of these proceedings. For such purpose, a person may need to ensure that a verbatim record of the proceedings is made, which record includes the testimony and evidence upon which the appeal is to be based.

NOTICE: In accordance with the Americans with Disabilities Act ("ADA") and Florida Statutes, Section 286.26, persons with disabilities needing a reasonable accommodation to participate in a public hearing or meeting should contact the City of Mount Dora's ADA Coordinator at least 48 hours prior to the proceeding. The ADA Coordinator may be contacted by phone at 352-735-7126, ext. 1111, or by email at clerk@cityofmounddora.com.

If hearing impaired, telephone the Florida Relay Service numbers (800) 955-8771 (TDD) or (800) 955- 8770 (Voice) for assistance.



**CITY OF
MOUNT
DORA**

**Leisure Services
900 N. Donnelly St.
Mount Dora, FL 32757
352-735-7183
Fax: 352-735-3681
E-mail: parksandrec@cityofmoundora.com**

DATE: May 27, 2025

TO: Public Arts Commission Members

FROM: Troy Shonk, Director of Parks and Recreation

SUBJECT: Election of 2025 Chair and Vice-Chair

Introduction:

According to the bylaws of the Public Arts Commission, at the first meeting of the calendar year, the commission shall elect one of its members as chairman and such officers as it finds necessary.

Discussion:

For the nomination of officers, the board shall consider the following procedure:

Current Chair will call the meeting to order and, after roll call, he/she will open the floor for nominations.

The Chair recognizes the member making the nomination:

“__(name)__, would you please state your name for the record and your nomination?”

Member:

“My name is __(name)__ and I would like to nominate __(name)__ for __(position)__.”

Chair asks the nominee if they consent to the nomination.

If nominee gives their consent, the Chair announces:

“__(name)__ has been nominated for the position of __(position)__. Are there any further nominations?”

Continue until there are no other nominations.

If there is only one nomination, the Chair declares the nominations closed.

“May I have a second motion to nominate __(name)__ as the new __(position)__?”

“Any discussion?”

“All those in favor/opposed?”

Motion carried. Passes/Fails.

If there are multiple nominations, the Chair will take a vote on each nomination in the order they were made.

After tallying the ayes and nays the Chair will announce the nominee that received the majority of the votes:

“_(name)_ has received the majority of the votes. May I have a motion and a second to accept the results of the vote?”

“Any discussion?”

“All those in favor/opposed?”

Motion carried by a voice vote of ____ to ____.

Passes/Fails.

The new Chairperson takes over the meeting at this point.

Budget Impact:

N/A

Strategic Impact:

N/A

Recommendation Commission members elect their 2025 Chair and Vice-Chair.

Attachment(s):

Prepared by: Jennifer Schwarz, Operations Manager
Reviewed by: carsonc carsonc, Special Events Manager
Troy Shonk, Parks & Recreation Director

Approved - 5/20/2025
Final Approval - 5/20/2025



CITY OF
MOUNT
DORA

Leisure Services
900 N. Donnelly St.
Mount Dora, FL 32757
352-735-7183
Fax: 352-735-3681
E-mail: parksandrec@cityofmounddora.com

DATE: May 27, 2025
TO: Public Arts Commission Members
FROM: Troy Shonk, Director of Parks and Recreation
SUBJECT: March 25, 2025 Public Arts Commission Meeting Minutes

Introduction:

This is a request for the Public Arts Commission to approve meeting minutes.

Discussion:

Administrative staff prepare minutes and present them to the Commission as an opportunity to make suggestions or corrections prior to final approval.

Budget Impact:

N/A

Strategic Impact:

Detailed minutes ensure that Commission meetings are well documented and votes are recorded for the public record.

Recommendation Commission approve minutes as transcribed.

Attachment(s):

1. 3.25.25 PAC Minutes

Prepared by: Jennifer Schwarz, Operations Manager
Reviewed by: carsonc carsonc, Special Events Manager
Troy Shonk, Parks & Recreation Director

Approved - 5/20/2025
Final Approval - 5/20/2025

**CITY OF
MOUNT DORA, FLORIDA
PUBLIC ARTS
COMMISSION
MINUTES**



**March 25, 2025
City Hall
510 N. Baker St.
Mount Dora, FL 32757**

CALL TO ORDER

Having been duly advertised as required by law, Chairperson Decker called to order the March 25, 2025, regular meeting of the Public Arts Commission at 3:30 P.M. in the City Hall Council Chambers.

ROLL CALL

Members Present:

Thomas Decker
Lindsay Perreault
Maryann McNamara
John Wesner

Also Present:

Troy Shonk, Parks & Recreation Director
Christopher Carson, Cultural & Special Events Manager
Jennifer Schwarz, Parks & Recreation Deputy Director
Gretchen Gomez, Parks & Recreation Admin Coordinator

Members Not Present:

Rebecca Owen
Jane Slivka
Kaeshawn Vomer

Election of 2025 Chair and Vice-Chair:

The election has been postponed onto the next meeting.

APPROVAL OF MINUTES

A. January 28, 2025 Meeting Minutes

MOTION TO APPROVE BY COMMISSION MEMBER MCNAMARA; COMMISSION MEMBER WESNER SECONDED THE MOTION. MOTION APPROVED BY A ROLL CALL VOTE.

*YES Chairperson Decker
Commission Member McNamara
Commission Member Wesner
Commission Member Perreault*

NO None

PUBLIC COMMENT

PRESENTATIONS

ACTION ITEMS

A. Purchase sculpture for the Art Walk at Simpson Cove

Discussion ensued regarding purchasing a sculpture for the Art Walk at Simpson Cove, where exactly it would be located, and how long would the sculpture be there for. Furthermore the commission discussed City staff working with Janet Gamache from Mount Dora Center for the Arts for the placement of sculpture.

MOTION BY COMMISSION MEMBER WESNER, SECONDED BY COMMISSION MEMBER MCNAMARA TO PURCHASE THE SCULPTURE, STAFF TO WORK WITH JANET GAMACHE AND A BOARD MEMBER ON THE LOCATION WITH THE INTENTION OF SCULPTURE GOING TO THE ART WALK AT SIMPSON COVE. MOTION APPROVED BY ROLL CALL VOTE.

*YES Chairperson Decker
Commission Member Wesner
Commission Member Perreault
Commission Member McNamara*

NO None

Paul Morris, Mount Dora Center for the Arts: Asked what is the overall goal of the sculpture being added to the Art Walk at Simpson Cove.

Daniel Stetson, retired Art Museum Director: Discussed the sculpture not being site specific and the ability to move it around to other spaces in the City.

Janet Gamache, Mount Dora Center for the Arts: Discussed purchasing the piece, moving it around, and the possibility of not needing to place it out to the public immediately.

B. Purchase a Projection Screen for the Mount Dora Music Hall in the Community Building

Ms. Perreault presented the purchase of a projection screen for the performing arts due to the performing arts being a part of the Public Arts Master Plan. Mr. Carson further outlined the importance of having an updated projection screen.

MOTION BY COMMISSION MEMBER MCNAMARA, SECONDED BY PERREAULT TO PURCHASE A PROJECTION SCREEN FOR THE MOUNT DORA MUSIC HALL IN THE COMMUNITY BUILDING. MOTION APPROVED BY ROLL CALL VOTE.

*YES Chairperson Decker
Commission Member Wesner
Commission Member Perreault
Commission Member McNamara*

NO None

Paul Morris, Mount Dora Center for the Arts: inquired about the size of the projection screen and commented on who should pay for it.

RESOLUTIONS

ORDINANCES

DISCUSSION ITEMS

A. Project Updates

Mr. Carson asked German Lemus from Studio Art Farm to update the board on the finished performing base piece. German Lemus suggested a possible walkway or stepping stones to get onto the performing base in order to avoid people stepping on the grass.

Mr. Carson discussed a potential mural on a utility wall on Dora Drawdy.

CITY STAFF

A. Staff Update

Mr. Carson informed the board that the Donation Receipt Form has been added to the Public Arts page, 2 new plaques for art pieces have been installed, and the Mount Dora Big Chair is being worked on.

COMMUNICATIONS AND REPORTS

A. Commission Member John Wesner

B. Chairperson Thomas Decker

C. Commission Member Jane Slivka

C. Commission Member Maryann McNamara Discussed Ormond Beach Life Sculptures.

E. Vice-Chairperson Keashawn “Kay” Volmar

F. Commission Member Rebecca Owen

G. Commission Member Lindsay Perreault

Discussed other performing art events like a Circus, Fringe Next Festival, Comedy Night, and Mount Dora Choir.

FUTURE MEETING DATES

A. May 27, 2025 3:30 p.m.

B. July 22, 2025 3:30 p.m.

C. September 23, 2025 3:30 p.m.

D. November 25, 2025 3:30 p.m.

ADJOURNMENT

MOTION BY COMMISSION MEMBER MCNAMARA TO ADJOURN; COMMISSION MEMBER WESNER SECONDED THE MOTION. MOTION APPROVED BY A UNANIMOUS VOICE VOTE.

There being no further business for discussion, the meeting adjourned at approximately 4:58 P.M.

THOMAS DECKER, CHAIRPERSON
City of Mount Dora

GRETCHEN GOMEZ, ADMIN COORDINATOR
City of Mount Dora



CITY OF MOUNT DORA

Leisure Services
900 N. Donnelly St.
Mount Dora, FL 32757
352-735-7183
Fax: 352-735-3681
E-mail: parksandrec@cityofmountdora.com

DATE: May 27, 2025

TO: Public Arts Commission Members

FROM: Troy Shonk, Director of Parks and Recreation

SUBJECT: Gift of Freenotes Harmony Park Sculpture - Cathy Lunday, Library Director

Introduction:

The Friends of the Library have donated a musical sculpture to the city's Nunan Butterfly Garden.

Discussion:

In recognition of Mount Dora's public library's 120th anniversary, the Friends of the Library have donated the "Cascade Bells" musical sculpture from FreeNotes Harmony Park for installation in the Nunan Butterfly Garden. This is the second musical sculpture in the garden; the "Swirl" giant xylophone was installed in 2023.

Freenotes Harmony Park instruments were originally developed by Grammy Award-winning musician Richard Cooke in 1995, who sought to give everyone the experience of playing music instinctively, without formal training or the ability to read music. The music emanating from these sculptures, which are constructed of durable anodized aluminum and tuned to a C major pentatonic scale, is always harmonious and pitch-perfect, making them accessible to all.

The installation of the "Cascade Bells" musical sculpture is planned for June 2025.

Budget Impact:

This gift, which was purchased by the Friends for \$5,515, has no additional financial costs.

Strategic Impact:

Initiative #2, Goal 4 - Work with outside organizations to beautify Mount Dora's public spaces.

Recommendation n/a

Attachment(s):

Prepared by: Jennifer Schwarz, Operations Manager
Reviewed by: Cathy Lunday, Library Director
carsonc carsonc, Special Events Manager
Troy Shonk, Parks & Recreation Director

Approved - 5/20/2025
Approved - 5/20/2025
Final Approval - 5/20/2025



CITY OF MOUNT DORA

Leisure Services
900 N. Donnelly St.
Mount Dora, FL 32757
352-735-7183
Fax: 352-735-3681
E-mail: parksandrec@cityofmoundora.com

DATE: May 27, 2025

TO: Public Arts Commission Members

FROM: Troy Shonk, Director of Parks and Recreation

SUBJECT: Noblewins Art Seating

Introduction:

The Public Arts Commission recognizes the importance of interactive art in public places.

Discussion:

This is an opportunity for members of the Public Arts Commission to consider artistic seating areas that consist of recyclable metal material. The company that produces seating structures is Noblewins, which has made a positive impact on art communities. There are a few examples of bench seating included in this agenda item that would compliment the Simpson Cove Art Walk area. Each bench area is primed and prepared for an artist to paint.

Budget Impact:

These are budgeted funds for public arts projects in GL code 001-1340-572.31-01.

Strategic Impact:

The Public Art Commission recognizes the need for projects that were approved within the Public Arts Master Plan.

Recommendation This is an opportunity for the Public Arts Commission to acquire seating art that benefits the Simpson Cove Art Walk experience.

Attachment(s):

1. Noblewins - Primed Public Art Guide
2. Mount Dora, FL - Art Walk Pieces
3. Mount Dora, FL - Art Walk Arch
4. Mount Dora, FL - Art Walk Acadia
5. Noblewins-Offloading-and-Surface-Mounting

Prepared by: carsonc carsonc, Special Events Manager
Reviewed by: carsonc carsonc, Special Events Manager
Troy Shonk, Parks & Recreation Director
Jennifer Schwarz, Operations Manager

Approved - 5/20/2025
Approved - 5/20/2025
Final Approval - 5/20/2025

TURNING YOUR BENCH INTO FUNCTIONAL ART



DESIGN MOCKUPS & ARTIST CALL-OUTS

We invite schools, artists, and community groups to submit mural designs for Noblewins pieces - each product is a unique canvas for creative expression. Product images for design mockups follow this one-pager. Artists can sketch directly on them, overlay digital designs, or submit concept art.

SURFACE INFO

Your Noblewins piece has been professionally primed with a water-based acrylic coating designed to bond to tough materials and provide excellent adhesion for mural paints and wraps.

- Primer: Sherwin-Williams Bond-Plex Water-Based Acrylic Coating
- Fully cured and ready to paint upon delivery
- No additional priming required

PAINTING A MURAL

Step 1: Prep the Surface

- Wipe clean with a damp cloth
- If dusty or slick, lightly scuff with 220-grit sandpaper and wipe again
- Ensure the surface is dry before painting

Step 2: Recommended Paints

- Sherwin-Williams Resilience, SuperPaint, or Duration Exterior Acrylic
- Nova Color Acrylic Artist Paints
- Behr Ultra or Marquee Exterior Acrylic Latex

Step 3: Optional Clear Coat for Protection

- Sher-Clear 1K (Sherwin-Williams)
- World's Best Graffiti Coating
- Golden MSA Varnish (Gloss or Satin) with UVLS
- Apply 1-2 coats once mural is fully dry (24-48 hrs)
- Always test a small area first for compatibility

VINYL WRAPPING (ALTERNATIVE TO PAINTING)

Recommended Vinyl Materials

- 3M Controltac Graphic Film IJ180
- Avery Dennison MPI 1105 SuperCast
- Orajet 3951RA + Oraguard 290 laminate

Application Tips

- Clean surface thoroughly
- Apply between 60°F-80°F
- Use heat guns and tools for curves
- Laminate for UV/graffiti protection



YOSEMITE

WIDTH: 60-72"

DEPTH: 24"

HEIGHT: 21"



BIG BEND

WIDTH: 72-84"

DEPTH: 24"

HEIGHT: 40"



NOBLEWINS



SEQUOIA

WIDTH: 72-84"

DEPTH: 30"

HEIGHT: 40"



NOBLEWINS

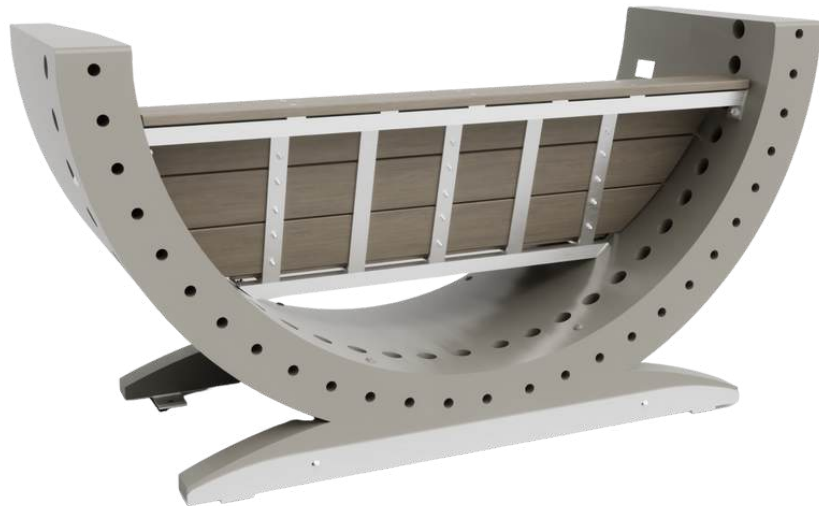
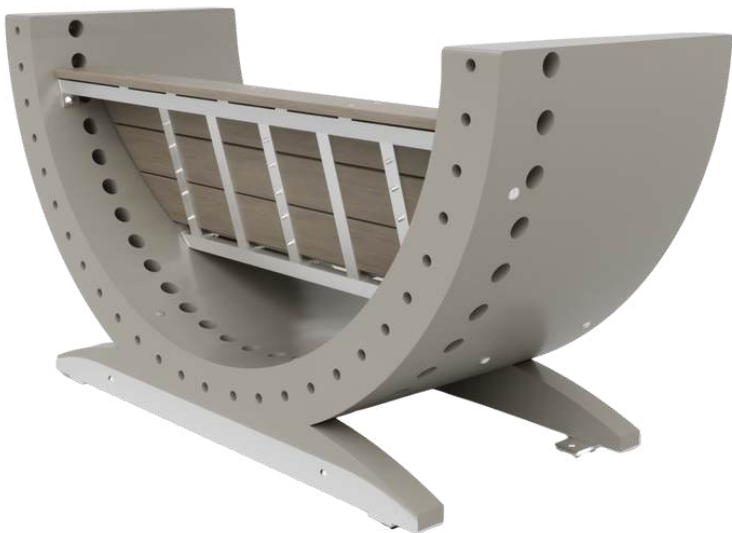

ZIÖ N

WIDTH: 8'

TABLE DEPTH: 24"

TABLE HEIGHT: 21"

SEAT DEPTH: 17"

SEAT HEIGHT: 18"



NOBLEWINS



ARCH

WIDTH: 90-96"

DEPTH: 36"

HEIGHT: 80-86"



NOBLEWINS



EVERGLADE

WIDTH: 90-96"

DEPTH: 36"

HEIGHT: 80-86"



NOBLEWINS



ACADIA

WIDTH: 50-70"

DEPTH: 30"

HEIGHT: 91-112"



NOBLEWINS





NOBLEWINS

Mount Dora, FL

510 N. Baker St
Mount Dora, FL 32757

Reference: 20250507-200135365

Quote created: May 7, 2025

Quote expires: May 31, 2025

Quote created by: Harper Weiss

Chris Carson

carsonc@cityofmountdora.com
(352) 735-7183 Ext. 1601

hweiss@noblewins.com

+14403069011

Comments from Harper

15% Pilot Program discount applied.
Freight cost included.

Products & Services



Image	Item & Description	Quantity	Unit Price	Total
	Acadia - Primed Bench comes primed and prepared for community artists to create their own custom mural design on-site.	1	\$5,995.00	\$5,995.00

Image	Item & Description	Quantity	Unit Price	Total
	<p>Arch - Primed</p> <p>Bench comes primed and prepared for community artists to create their own custom mural design on-site.</p>	1	\$7,975.00	\$7,975.00

One-time subtotal	\$13,970.00
15% Pilot Program Discount applied	(\$2,095.50) 15% discount
Freight Cost	\$1,650.00
Total	\$13,524.50

[Terms & Conditions](#)

Signature

Signature

Date

Printed name

Questions? Contact me



Harper Weiss

hweiss@noblewins.com

+14403069011

Noblewins

PO Box 16039

Rocky River OH 44116

United States



NOBLEWINS

Mount Dora, FL

510 N. Baker St
Mount Dora, FL 32757

Reference: 20250507-174702369

Quote created: May 7, 2025

Quote expires: May 31, 2025

Quote created by: Harper Weiss

Chris Carson

carsonc@cityofmountdora.com
(352) 735-7183 Ext. 1601

hweiss@noblewins.com

+14403069011

Comments from Harper

10% Primed Discount Applied.
Freight Cost Included.

Products & Services

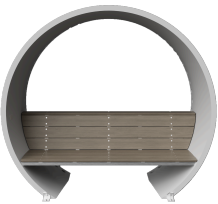
Image	Item & Description	Quantity	Unit Price	Total
	Arch - Primed Bench comes primed and prepared for community artists to create their own custom mural design on-site.	1	\$7,975.00	\$7,975.00

One-time subtotal	\$7,975.00
<hr/>	
10% Primed Discount applied for all primed pieces. Expiring 5/31	(\$797.50) 10.0% discount
<hr/>	
Freight Cost	\$1,650.00
<hr/>	
Total	\$8,827.50

[Terms & Conditions](#)

Signature

Signature

Date

Printed name

Questions? Contact me



Harper Weiss
hweiss@noblewins.com
+14403069011

Noblewins
PO Box 16039
Rocky River OH 44116
United States



NOBLEWINS

Mount Dora, FL

510 N. Baker St
Mount Dora, FL 32757

Reference: 20250328-120129782

Quote created: March 28, 2025

Quote expires: May 31, 2025

Quote created by: Harper Weiss

Chris Carson

carsonc@cityofmountdora.com
(352) 735-7183 Ext. 1601

hweiss@noblewins.com

+14403069011

Comments from Harper

10% Primed Discount Applied.
Freight Cost Included.

Products & Services

Image	Item & Description	Quantity	Unit Price	Total
	Acadia - Primed Bench comes primed and prepared for community artists to create their own custom mural design on-site.	1	\$5,995.00	\$5,995.00

One-time subtotal	\$5,995.00
<hr/>	
10% Primed Discount applied for all primed pieces. Expiring 5/31.	(\$599.50) 10.0% discount
<hr/>	
Freight cost.	\$1,650.00
<hr/>	
Total	\$7,045.50

[Terms & Conditions](#)

Signature

Signature

Date

Printed name

Questions? Contact me



Harper Weiss
hweiss@noblewins.com
+14403069011

Noblewins
PO Box 16039
Rocky River OH 44116
United States

OFFLOADING & SURFACE MOUNTING GUIDE

Open Collection: Yosemite, Big Bend, Zion, Sequoia

Mounting Hardware (Not Included)

1/2" x 4-1/4"
wedge anchor

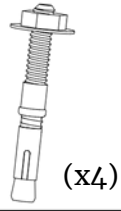

Tools & Equipment



forklift



3/4" socket



9/16" drill bit
for concrete

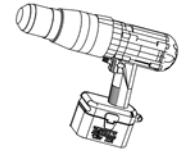

hammer drill

Offloading and Anchoring Guide

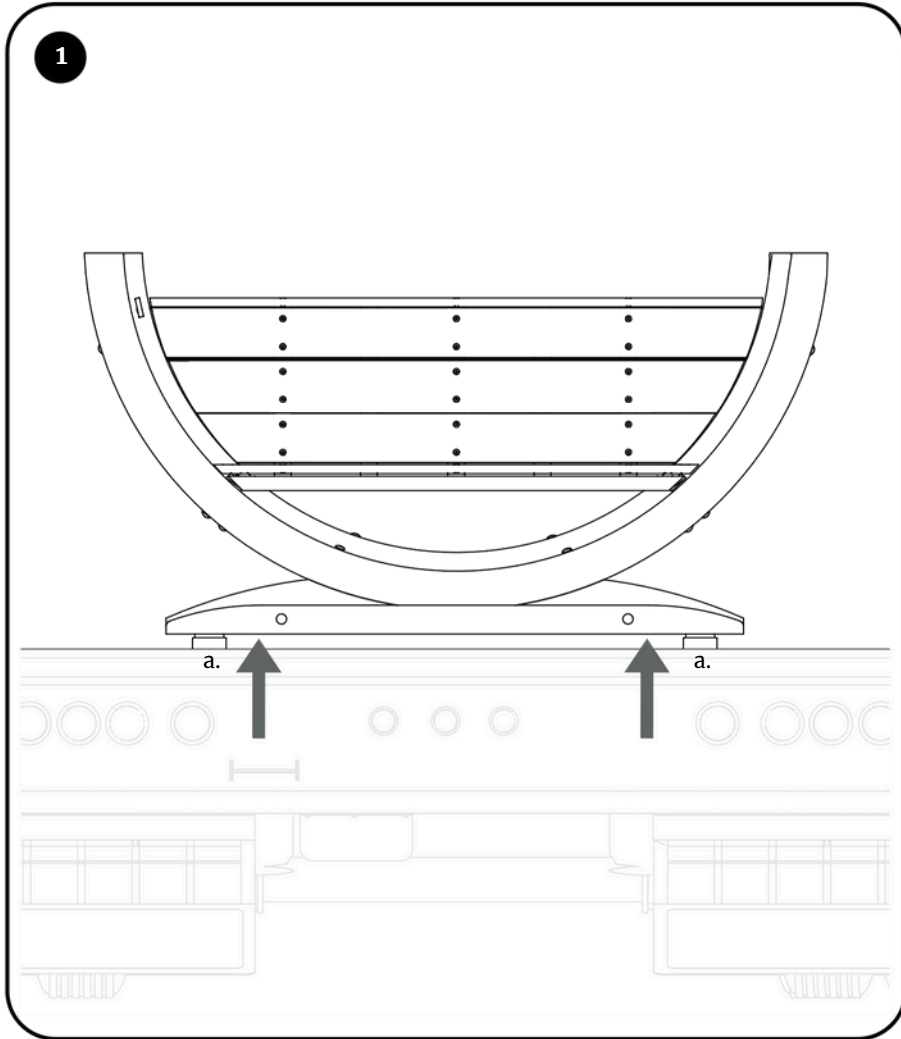

Offloading

Arrows indicate lifting points. Noblewins recommends the use of padding between forks and bench contact points.

(a.) Wooden shipping frames to be removed prior to final placement of bench.

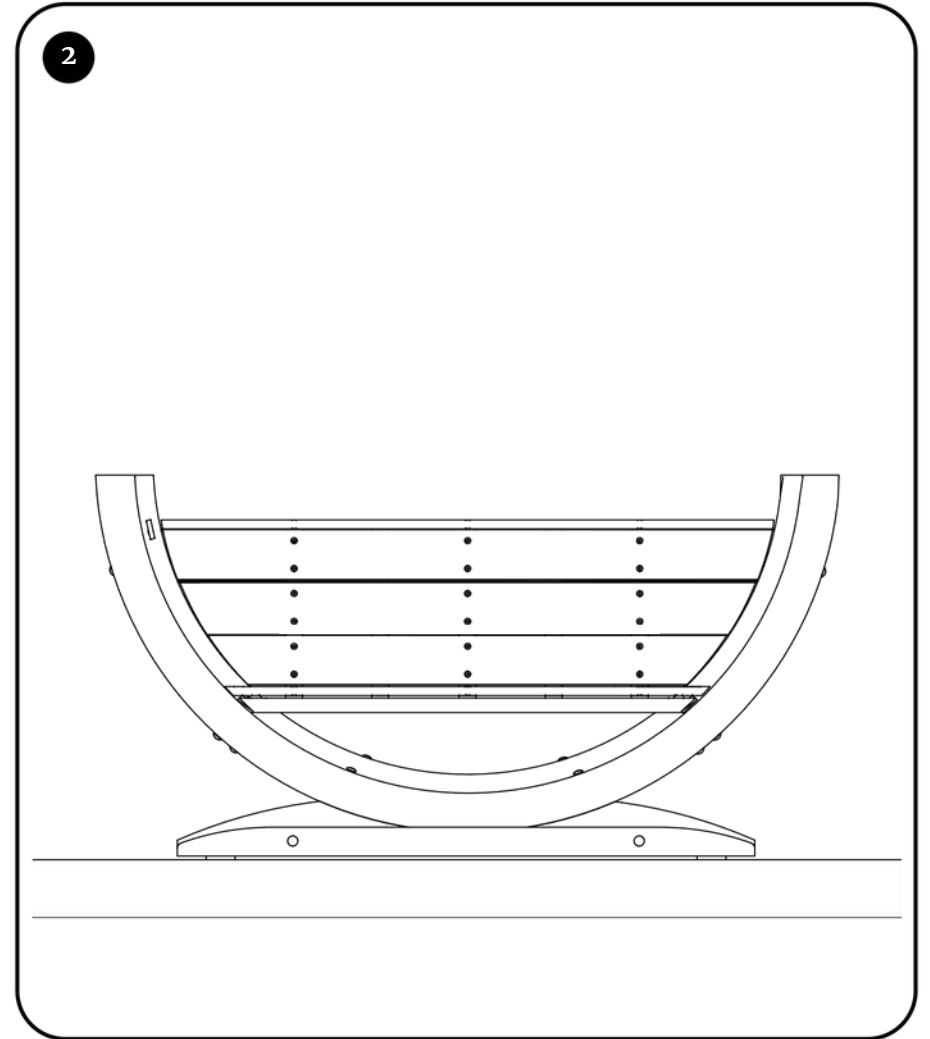

Placement

Prior to placing the bench in desired location, remove wooden shipping frames.

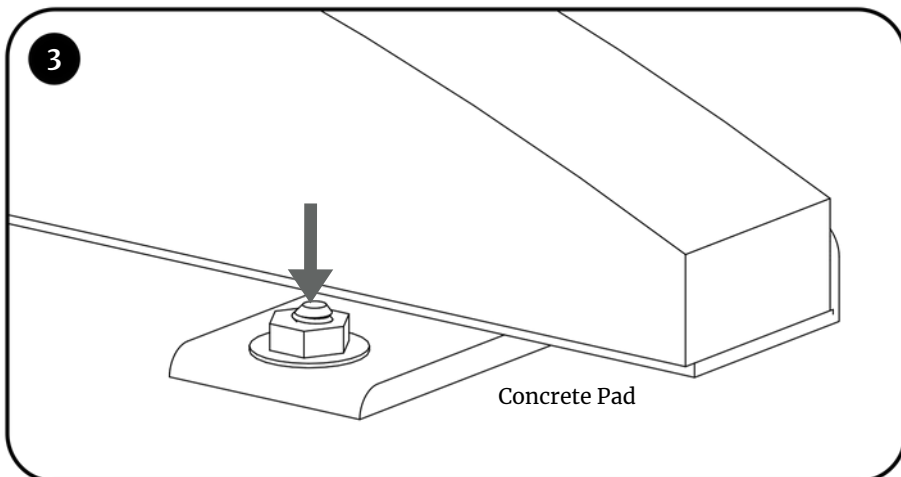

Anchoring Drill holes and drive wedge anchors fully into place.

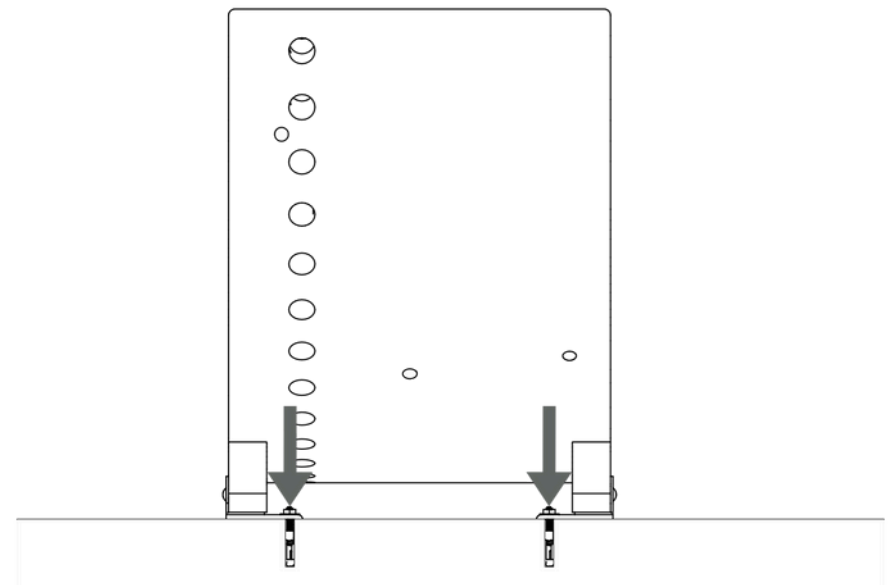

OFFLOADING & SURFACE MOUNTING GUIDE

Shaded Collection: Arch, Everglade

Mounting Hardware (Not Included)

1/2" x 4-1/4"
wedge anchor

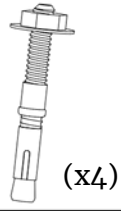

Tools & Equipment



forklift



nylon straps (x2)



3/4" socket

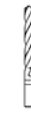

9/16" drill bit
for concrete

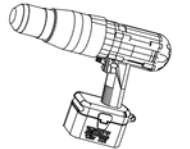

hammer drill

Offloading and Anchoring Guide

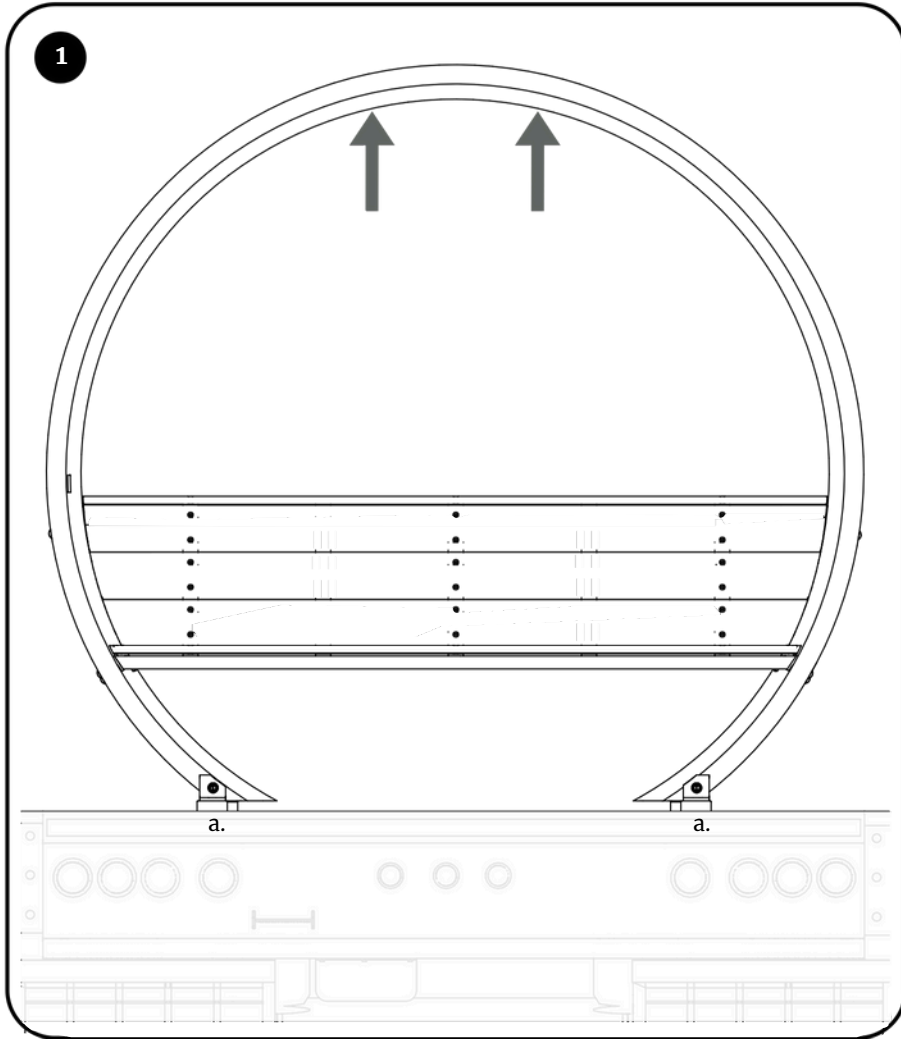

Offloading

Arrows indicate lifting points. Noblewins recommends the use of nylon straps when moving products within the Shaded Collection, with additional padding between straps and bench contact points.

(a.) Wooden shipping frames to be removed prior to final placement of bench.

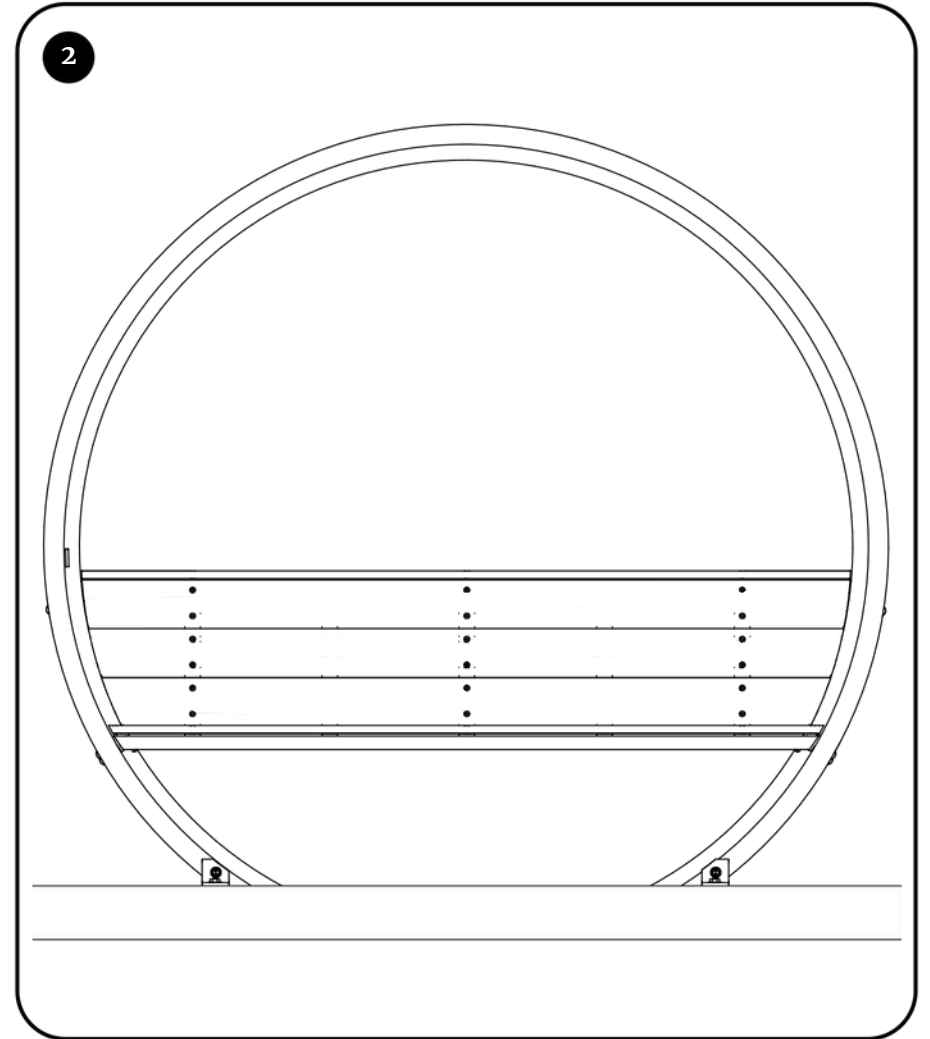

Placement

Prior to placing the bench in desired location, remove wooden shipping frames.

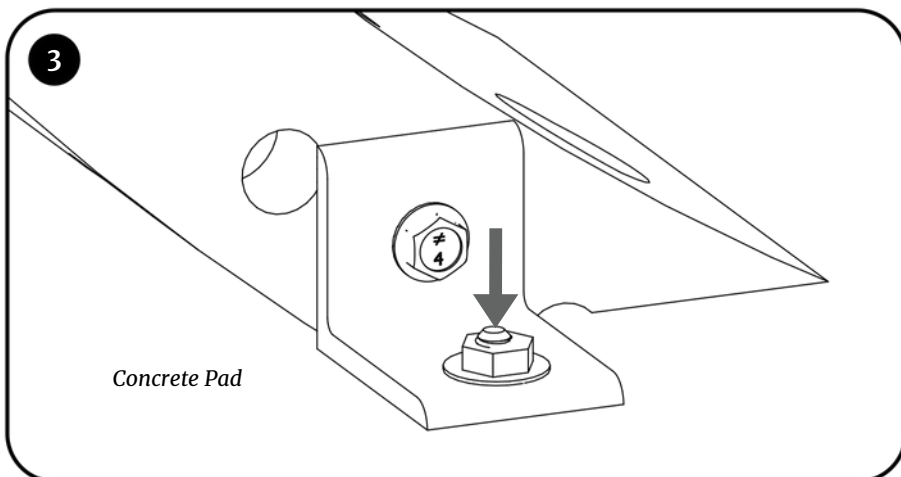

Anchoring Drill holes and drive wedge anchors fully into place.

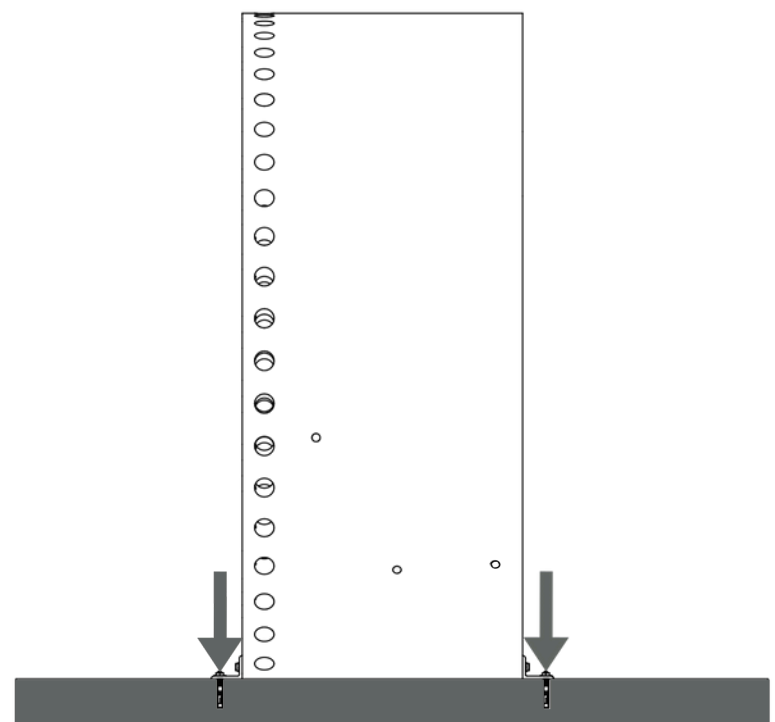



**CITY OF
MOUNT
DORA**

**Leisure Services
900 N. Donnelly St.
Mount Dora, FL 32757
352-735-7183
Fax: 352-735-3681
E-mail: parksandrec@cityofmoundora.com**

DATE: May 27, 2025
TO: Public Arts Commission Members
FROM: Troy Shonk, Director of Parks and Recreation
SUBJECT: Release of Reserved Funds for the Aerial Display Program

Introduction:

Due to the Aerial Banner Display not occurring in the current budget year, this allows an opportunity to reallocate funds for other projects.

Discussion:

Members of the Public Arts Commission earmarked funds from the approved budget for projects such as the Aerial Banners that Commissioner Kay Volmar presented. At this time, Ms. Volmar has decided not to move forward with the Aerial Display Banner Program and to release the funds that were allocated.

Budget Impact:

There was \$20,000 allocated for the Aerial Banner Display Program, as part of the budget GL code 001-1340-572.31-01.

Strategic Impact:

The Public Art Commission recognizes the need for projects that were approved within the Public Arts Master Plan.

Recommendation Staff recommends releasing the funds of \$20,000 set aside for the Aerial Banner Display for other purposes that are approved by members of the Public Arts Commission.

Attachment(s):

Prepared by: carsonc carsonc, Special Events Manager
Reviewed by: carsonc carsonc, Special Events Manager

Approved - 5/20/2025

Troy Shonk, Parks & Recreation Director
Jennifer Schwarz, Operations Manager

Approved - 5/20/2025
Final Approval - 5/20/2025



**CITY OF
MOUNT
D O R A**

Leisure Services
900 N. Donnelly St.
Mount Dora, FL 32757
352-735-7183
Fax: 352-735-3681

E-mail: parksandrec@cityofmoundora.com

DATE: May 27, 2025

TO: Public Arts Commission Members

FROM: Troy Shonk, Director of Parks and Recreation

SUBJECT: Staff Update

Introduction:

Staff Update

Discussion:

Updates to include:

- * The large Adirondack Chair has been repainted and returned to Grantham Pointe.
 - * Letter "E" sculpture art by artist Kenneth Sandlin has been installed as part of the Simpson Cove Art Walk.
 - * Projection Screen has been ordered for the Music Hall in the Community Building.
 - * Pavers have been installed to complement the interactive art area.
 - * Landscaped rocks around Heron Sculpture.
- * Suggest Members of the Public Arts Commission submit art project items prior to the next meeting to be included for discussion and potential approval.

Budget Impact:

N/A

Strategic Impact:

N/A

Recommendation

Attachment(s):

Prepared by: Jennifer Schwarz, Operations Manager
Reviewed by: carsonc carsonc, Special Events Manager
Troy Shonk, Parks & Recreation Director

Approved - 5/20/2025
Final Approval - 5/20/2025